

APPLICATION STORY OF AN MPL PRODUCT

Canaz Corporation

Canaz does nature documentary films in extreme environmental conditions.

Application

Canaz uses real-time full-motion digital cameras to do nature photography. The PIP6 will be used to collect and archive the digital images.

We have used the 80mm case on the PIP6 to increase the size of the cavity inside so that two 2.5" hard drives can be 'piggybacked' to provide maximum disk storage. With present technology this means that we can have up to 64GB of on-line data storage (using two IBM 32Gb 2.5" EIDE hard drives).

The Sony digital cameras presently use a SCSI-II interface, but future releases will need IEEE-1394 Firewire ports. The PIP6 was used rather than the PIP5 so that a PC/104plus Firewire card can be added in the future.

A Sony DAT tape backup system is also attached externally using the SCSI-II interface.



Construction that hold the camera, battery and PIP6

Reasons for using MPL products

This particular unit was used in Russia and in the Arctic circle to do a documentary on the Beluga whale. Reliability, robustness, the low power consumption where key as it had to run from Batteries that where recharged by solar panels. The integrated SCSI-II interface, and the PC/104plus bus were further key reasons for choosing the MPL product

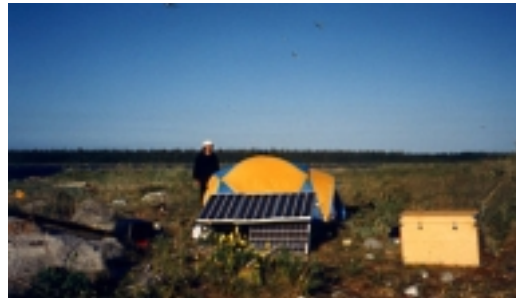

Recharging the batteries that supply the PIP



View of the complete construction

Block diagram of System

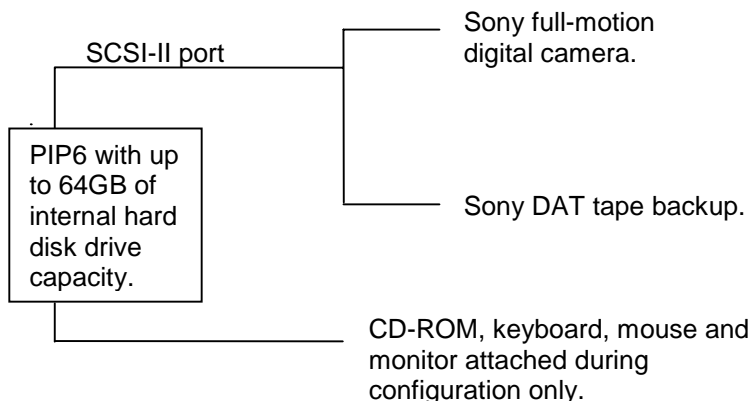

MPL products used

PIP6-1 packaged system with the PIP80 80mm housing.

The 4GB hard drive was removed and an 18GB IBM hard drive inserted (future systems will have more hard drive space).